

FITTING INSTRUCTIONS

CLOUD CONNECTED RECEIVER

M2C-S-2



WIRE CONNECTIONS: There are three wires that connect the Receiver to the vehicle: red, black, and green.

- Connect the **RED** wire (positive) directly to a 12/24V permanent power supply.
- Connect the **BLACK** wire (negative) to a known negative eg. chassis.
- Connect the **GREEN** wire (ignition) to a 12/24V ignition power supply.

Please ensure supplies are protected with a 1 amp fuse.

Fitting the Receiver

1.

The Receiver should be fitted close to the middle of the chassis, equidistant between front and rear axles, with the Wheely-Safe logo facing the ground. See the diagrams for rigid and articulated vehicles below. For special vehicle types, please contact Wheely-Safe for advice.

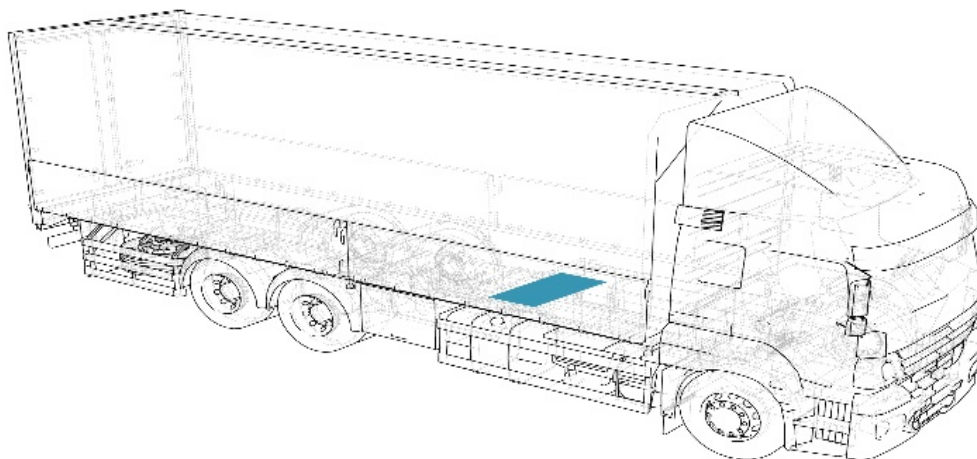

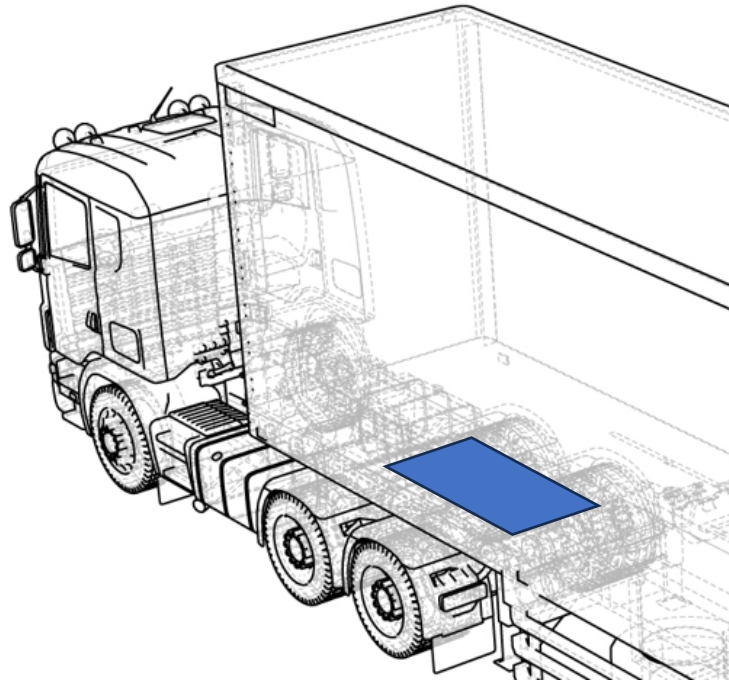

2.

Make sure that the fitment area is clear of rust, moisture, dirt and grease prior to fitment.

3.

To aid fixing the Receiver, remove the backing from the adhesive pad at the rear of the Receiver, taking care not to touch the exposed adhesive surface.

Position the RECEIVER in the desired location and press the adhesive pad firmly onto the fitment surface for a minimum of 10 seconds to allow for maximum adhesion.

A permanent fixing method is recommended utilising the mounting holes provided.

